

Air conditioning unit with cross-counterflow heat exchanger for private swimming pool halls



Automatically selects the most economical operating mode!



ThermoCond 19 20 01 and 29 20 01 - simplified illustration

ThermoCond 19 and 29

AIR VOLUME FLOW: 1,100 - 3,500 m³/h

At a glance:

- ▶ **Dehumidifies, ventilates and heats**
- ▶ **Corrosion-free heat exchanger made from polypropylene**
- ▶ **Two-stage recuperative heat recovery**
- ▶ **Energy-saving EC fans**
- ▶ **Integrated heat pump (ThermoCond 29)**
- ▶ **Constantly regulated recirculation air heating damper**
- ▶ **Variable air duct connections**
- ▶ **Compact design for minimal space requirements**
- ▶ **Integrated control and regulation system, compatible with all conventional building management systems**
- ▶ **Optional: operation via smartphone or tablet**

Devices of the series 19 and 29 dehumidify and heat the swimming pool hall and they reduce a possible concentration of harmful substances in the air. The devices are multifunctional compact systems with integrated control and regulation. ThermoCond 19 is suitable for swimming halls with lower heating requirements. ThermoCond 29 is

equipped with an integrated heat pump. This increases the overall efficiency of the system and enables the dehumidification of the pool hall air in recirculation mode. The design ensures the cleanability according to VDI 6022.

Further performance parameters and options:

- Filtering the air in any operating mode
- pumped hot water air heater
- sound-optimised plastic impellers for even quieter operation (from 19 20 01)
- Individually controllable performance parameters
- Complete unit, ready to connect, contains all structural elements for air conditioning swimming pool hall air, including all control and regulation fittings
- Intensive quality inspection with factory test run

- Options
- bypass damper
 - water/air temperature interconnection
 - design complies with VDI 6022
 - Pool water condenser (ThermoCond 29)
 - Domestic heat pump coupling (ThermoCond 29)
 - remote maintenance
 - and many more

Functional description

Dehumidification using outside air in winter

ThermoCond19: The swimming pool hall is dehumidified through the addition of outside air to the recirculated air volume flow. The proportion of outside air is continuously and automatically adjusted, depending on the current evaporation of water (occupancy level of the swimming pool hall), as well as the outside air humidity. This If the waste heat recovery is not sufficient for achieving the desired supply air temperature, the supply air is

Dehumidification using outside air in summer

In case of rising outside air humidity, the recirculation air damper is continuously closing as required. When the outside air

Recirculating air dehumidification (ThermoCond 29)

The air is dehumidified in the evaporator of the heat pump, this process is boosted by the pre-cooling effect in the heat exchanger. The air that has already cooled down and been dried is preheated in the heat exchanger by the return air from the swimming pool hall. On the other side of the heat exchanger, the transmission of heat produces a precooling effect, lowering the temperature of the drawn-in hu-

Domestic heat pump operation (ThermoCond 29)

An existing domestic heat pump can be used for energy-efficient heating of the swimming pool hall air. The domestic heat pump is connected to the heating coil. Typically, the low flow temperatures of the domestic heat pump are not sufficient for heating the swimming pool hall air – the heating coil is therefore

Recirculating Air Operation (heating)

If no requirements are placed on temperature regulation or dehumidification when the device is in standby mode, the system operates only in recirculation mode with reduced air volume flow. The air circulation in the swimming pool hall is guaranteed. If heating is required, the return air is heated up using the heating coil to achieve the supply air temperature set-point.

reheated in the heating coil.

ThermoCond29: A large proportion of the sensitive and latent heat is recovered from the return air, and is transferred to the supply air in the cross-counterflow heat exchanger and evaporator. If the heat output of the heat pump is not sufficient, the supply air will be reheated using the heating coil. Excess heat can be transferred to the optionally available pool water condenser for heating the pool water.

humidity is high, the damper closes completely. The system works at 100% outside air / exhaust air operation through the heat exchanger.

mid and warm air from the swimming pool hall near to its dew point. The preheated, dehumidified air is then mixed with a proportion of untreated recirculation air, is reheated at the condenser of the heat pump using the heat extracted during the dehumidification process, and is returned to the swimming pool hall as supply air. The heat pump is optimally designed, with a dehumidification energy requirement < 0.25 kWh/kg. If required, the supply air will be reheated using the heating coil.

installed upstream of the air condenser of the integrated heat pump. The domestic heat pump can so be operated with an optimal COP without a change in the low flow temperatures. In combination, the two systems heat the supply air to the desired temperature level.

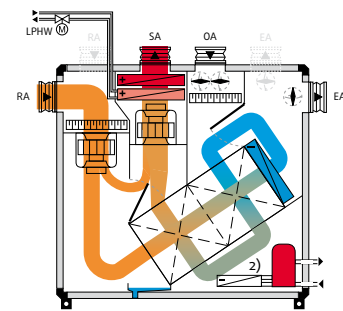
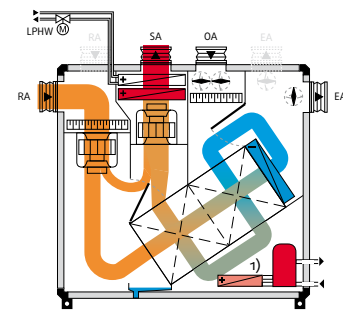
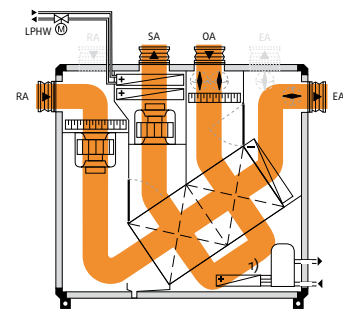
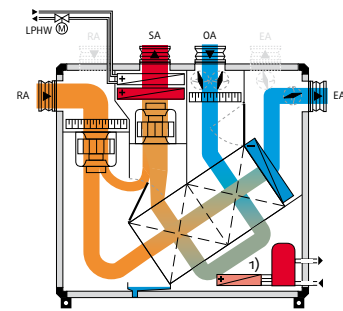
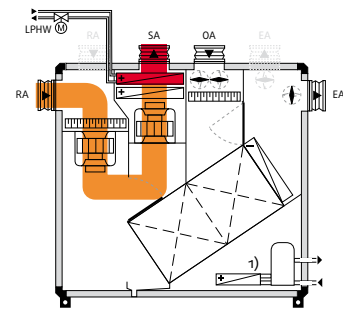

All images show ThermoCond 29 with heat pump.

- 1 Option: pool water condenser
- 2 Option: domestic heat pump operation

ThermoCond Type 19 and 29

System dimensions and weights

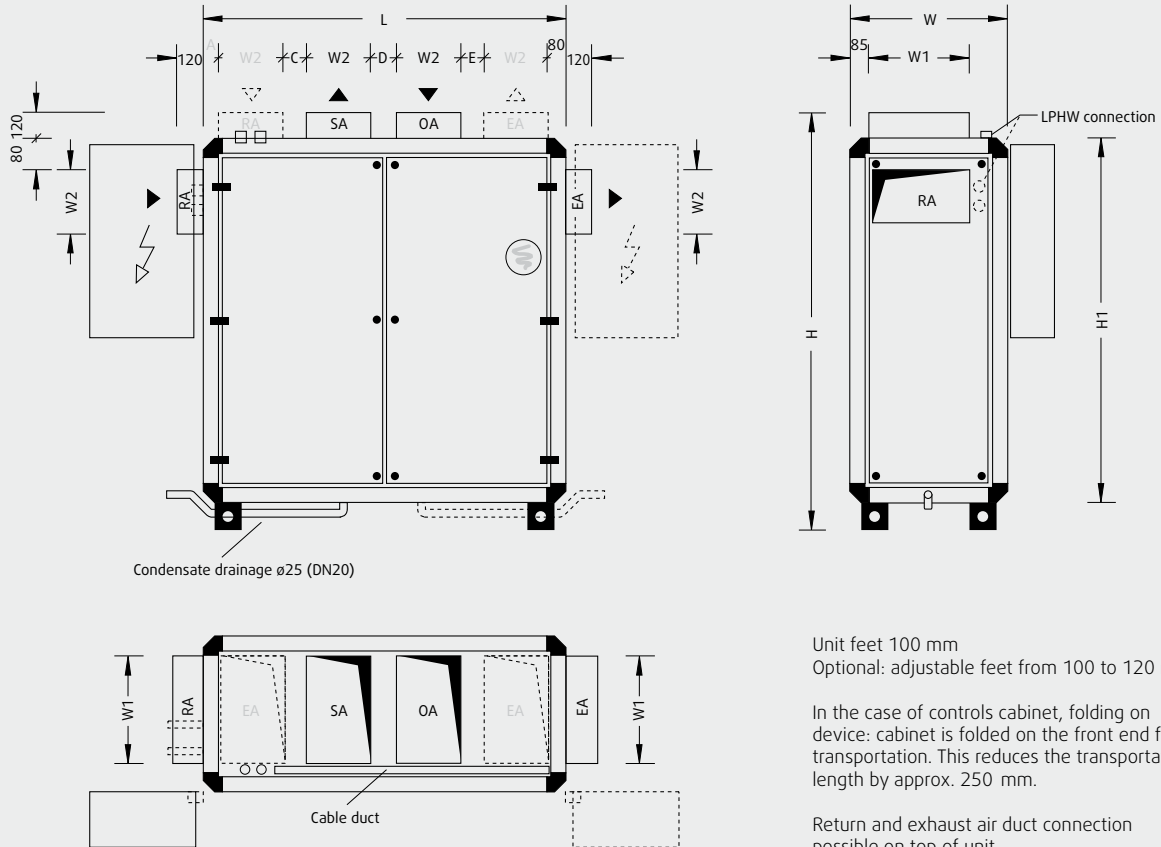

Unit feet 100 mm
Optional: adjustable feet from 100 to 120 mm

In the case of controls cabinet, folding on device: cabinet is folded on the front end for transportation. This reduces the transportation length by approx. 250 mm.

Return and exhaust air duct connection possible on top of unit.
Mirror-image design possible.

Unit type	L	W ¹	H ²	W1	W2	H1	A	C	D	E	Weight Type 19	Weight Type 29
19 11 01	1,530	570	1,590	350	200	1,370	215	150	150	135	410	460
19 15 01	1,530	730	1,590	500	200	1,370	215	150	150	135	440	500
19 20 01	1,690	730	1,910	500	300	1,690	80	105	120	105	540	600
19 25 01	1,690	890	1,910	600	300	1,690	80	105	120	105	610	680
19 35 01	1,690	1,210	1,910	920	300	1,690	80	105	120	105	720	830

Controls cabinet

Unit Type	H x W x D	Position at unit
19 11 01	600 x 600 x 200	SA/RA side
19 15 01	600 x 600 x 200	SA/RA side
19 20 01	600 x 600 x 200	SA/RA side
19 25 01	600 x 600 x 200	SA/RA side
19 35 01	600 x 600 x 200	SA/RA side

For service work, a clearance corresponding to dimension B is required on the operating side of the unit. If dimension W is smaller than one metre, please leave a clearance of one metre.

Please comply with the dimensions for body size, air duct connections and electrical controls cabinet.

Partitioning of unit for smaller apertures possible (at extra cost).

All lengths are given in mm, weights in kg.

- 1 Door fitting assembly increase unit width by 25 mm each operating side
- 2 incl. 100 mm unit feet,
incl. 120 mm duct connection

Technical specifications and services ThermoCond 19

Unit Type		19 11 01	19 15 01	19 20 01	19 25 01	19 35 01
Optimum flow rate	m ³ /h	1,100	1,500	2,000	2,500	3,500
Dehumidification capacity according to VDI 2089	kg/h	7.1	9.7	12.9	16.2	22.6
Total electrical power rating ¹	kW	0.94	1.05	1.45	1.65	2.66
Max. current consumption ¹	A	3.3	3.3	3.8	3.8	7.6
Operating voltage		3 / N / PE 400 V 50 Hz				
Ext. pressure losses						
Supply and fresh air channel	Pa	300	300	300	300	300
Return and exhaust air channel	Pa	300	300	300	300	300
Sound power level ²						
Supply air vent	dB(A)	79	78	68	66	73
RA connection	dB(A)	69	67	59	60	61
Outside air vent	dB(A)	65	63	54	54	59
EA connection	dB(A)	71	65	58	58	61
Acoustic pressure at a distance of 1 m from the device ²	dB(A)	63	59	49	48	54
Fan units						
Rated motor input for supply air ³	kW	0.55	0.60	0.81	0.92	1.54
Rated motor input for return air ³	kW	0.39	0.45	0.64	0.73	1.12
Rated motor input for supply air recirc mode ³	kW	0.22	0.26	0.36	0.48	0.64
Rated motor input for return air recirc mode ³	kW	0.22	0.26	0.36	0.48	0.64
SFP category (supply air return air) recirc mode		2 2	2 2	2 2	2 2	2 2
Nominal rating supply air return air	kW	1.0 1.0	1.0 1.0	1.2 1.2	1.2 1.2	2.4 2.4
Filtration according to DIN EN 779						
Outside air		M5				
Return air		M5				
LPHW						
Heating capacity ⁴ recirc mode	kW	8.5	12.1	14.6	18.9	26.6
Heating capacity ⁴ OA-EA operation	kW	10.4	14.9	17.9	23.2	32.3
Water flow rates and pressure losses						
LPHW	m ³ /h kPa	0.46 3.9	0.65 8.6	0.78 4.2	1.01 7.7	1.41 7.1
LPHW valve	m ³ /h kPa	0.46 8.1	0.65 16.6	0.78 9.8	1.01 16.5	1.41 12.5
Connections						
LPHW connection	DN	15	15	20	20	20
LPHW control valve connection	DN	10	10	15	15	20
Condensate drainage	DN	20	20	20	20	20
Floor drain	DN	20	20	20	20	20

Specifications of technical data relate to the optimum flow rate and return air condition 30° C / 54% r.h., outside air condition 15° C / 84% r.h. and standard density (1.204 kg/m³), unless otherwise specified.

- 1 depends on configuration of measurement and control system/unit
- 2 at 250 Hz mid-band frequency
- 3 with average filter contamination
- 5 FL/RL = 70/50° C, SA = 50° C

Please seek approval of technical data and specifications prior to start of the planning process.

Technical specifications and services ThermoCond 29

Unit Type		29 11 01	29 15 01	29 20 01	29 25 01	29 35 01
Optimum flow rate	m ³ /h	1,100	1,500	2,000	2,500	3,500
Dehumidification capacity according to VDI 2089	kg/h	7.1	9.7	12.9	16.2	22.6
Dehumidification capacity in recirc mode	kg/h	4.6	5.2	6.9	8.5	12.0
Heating capacity of heat pump ¹	COP	5.14	6.42	5.82	6.61	6.14
Total electrical power rating ²	kW	1.07	1.18	1.64	1.84	3.04
Max. current consumption ²	A	7.5	7.5	8.9	10.1	17.6
Operating voltage		3 / N / PE 400 V 50 Hz				
Ext. pressure losses						
Supply and fresh air channel	Pa	300	300	300	300	300
Return and exhaust air channel	Pa	300	300	300	300	300
Sound power level ³						
Supply air vent	dB(A)	76	77	66	64	71
RA connection	dB(A)	71	70	61	61	64
Outside air vent	dB(A)	66	64	56	55	60
EA connection	dB(A)	69	66	58	56	61
Acoustic pressure at a distance of 1 m from the device ³	dB(A)	62	61	51	49	56
Fan units						
Rated motor input for supply air ⁴	kW	0.60	0.65	0.89	1.00	1.70
Rated motor input for return air ⁴	kW	0.47	0.53	0.75	0.84	1.34
Rated motor input for supply air recirc dehumidification ⁴	kW	0.29	0.33	0.47	0.58	0.86
Rated motor input for return air recirc dehumidification ⁴	kW	0.35	0.40	0.57	0.68	1.06
SFP category (supply air return air) recirc dehumidification		2 2	1 2	1 2	1 2	2 2
Nominal rating supply air return air	kW	1.0 1.0	1.0 1.0	1.2 1.2	1.2 1.2	2.4 2.4
Integrated heat pump						
Filling volume of refrigerant type R407C ⁵ (without with PWC)	kg	2.0 3.0	2.0 4.0	3.0 4.0	3.0 4.0	4.0 5.0
Heating capacity heat pump	kW	7.2	7.7	9.9	11.9	17.2
Rated compressor input for recirc air dehumidification	kW	1.4	1.3	1.7	1.9	2.9
Rated compressor input for OA-EA operation ⁷	kW	1.4	1.2	1.7	1.8	2.8
Filtration according to DIN EN 779						
Outside air				M5		
Return air				M5		
LPHW						
Heating capacity ⁶ recirc mode	kW	6.7	9.1	11.7	14.6	21.3
Heating capacity ⁶ OA-EA operation	kW	2.9	5.7	7.4	9.7	13.7
Water flow rate and pressure losses						
LPHW	m ³ /h kPa	0.13 1.6	0.25 2.2	0.32 3.9	0.42 3.7	0.60 8.4
LPHW (pump warm water) valve	m ³ /h kPa	0.13 1.6	0.25 2.5	0.32 4.1	0.42 7.0	0.60 14.0
Pool water condenser ⁷ (supplementary equipment)						
Heating power ⁸	kW	6.4	7.0	9.0	11.0	15.5
Spread of pool water temperature	K	7.8	6.7	7.0	6.8	6.7
Pool water volume flow rate	m ³ /h	0.7	0.9	1.1	1.4	2.0
water side pressure loss	kPa	12.3	14.1	12.0	12.5	15.2
Connections						
LPHW connection	DN	15	15	15	15	15
LPHW control valve connection	DN	10	10	10	10	15
Condensate drainage	DN	20	20	20	20	20
Floor drain	DN	20	20	20	20	20
PWC connection ⁹	DN	20	20	25	25	25

Specifications of technical data relate to the optimum flow rate and return air condition 30° C / 54% r.h., outside air condition 15° C / 84% r.h. and standard density (1.204 kg/m³), unless otherwise specified.

- 1 dehumidifying in recirc mode without PWC
2 depends on configuration of measurement and control system/unit

- 3 at 250 Hz mid-band frequency
4 with average filter contamination
5 where domestic heat pump coupling; Refrigerant type = R134a; filling volumes vary
6 FL/RL = 70/50° C, SA ≈ 50° C
7 heat emission full and proportional; when water inlet temp. 28° C
8 dehumidifying in recirc mode with PWC

- 9 for units with pool water condensers

Please seek approval of technical data and specifications prior to start of the planning process.